

XLGCM06-D

Support de plafond pour caméra PTZ de la série de dissuasion active



Support

Application	Intérieur/Extérieur
Dimensions	104 x 131 x 67 / 4.1" x 5.2" x 4.6"
Poids	0.19 lb / 0.088 kg
Matériel	Alliage d'aluminium

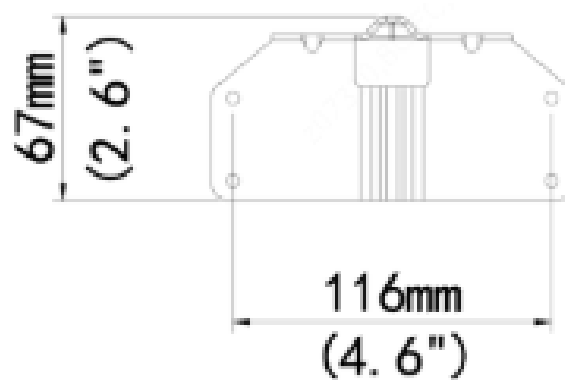
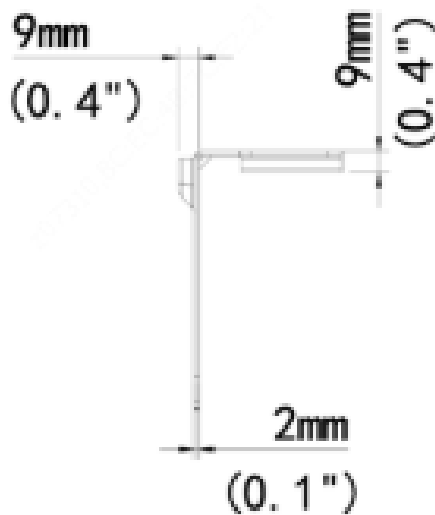
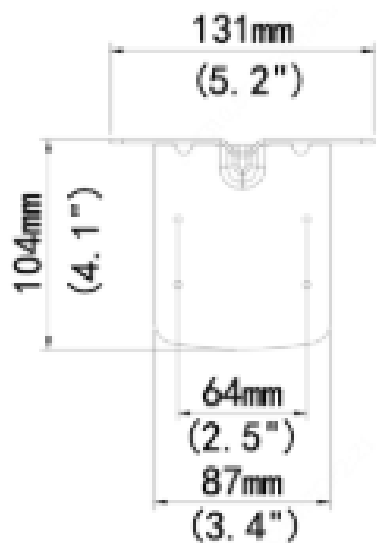

*Les dimensions et graphiques sont sujet aux changements sans préavis.